

# The Solutions for Light Duty Applications

## EMC and EMW Models



**300 & 500 Lb.**  
Made in USA

**500 Lb.**  
Made in USA

**COFFING EMC & EMW Models** - Compact chain and wire rope hoists designed for a variety of light duty applications. These models feature thermally protected motors.

- **CAPACITIES & LIFT** - Rated loads 300 and 500 pounds. 10-foot lift with 6-foot push button cord standard.
- **VOLTAGES** - 115V, single phase motors only.
- **SUSPENSION** - Swivel top and bottom hooks with safety latches standard.
- **POWER CORD** - Provided with grounded 3-prong plug for easy installation in any standard 115V outlet.
- **ALUMINUM HOUSING**- Lightweight and compact to provide strength and portability. Weighs less than 25 lb.
- **LIMIT SWITCHES** - Upper and lower limit switches on chain models and upper paddle limit switch on wire rope model regulates load travel.
- **ELECTROMAGNETIC BRAKE** - Quick acting for positive load control.
- **THERMAL MOTOR PROTECTION** - Standard to prevent overheating.
- **LIGHT DUTY OPERATION** - Rated for intermittent duty applications (10-minute run time per hour maximum).
- **ACCESSORIES** - LCC-05 chain container (shown) available for EMC models.
- **UL LISTED**
- **LIFETIME WARRANTY**

## SPECIFICATIONS

### EMC and EMW Models

Capacity (Lb.)	Model Number	No. of Chains	Standard Lift (Ft.)	Motor HP	Lift Speed (FPM)	Headroom (In.)	Housing Dimensions (In.)			Net Wt. (Lb.)
							H	W	L	
300	<b>EMC-300B</b>	1	10	1/6	16	14 1/2	4 3/8	6 3/8	14 1/4	21
500	<b>EMC-500B</b>	2	10	1/6	8	16	4 3/8	6 3/8	14 1/4	24
500	<b>EMW-500B</b>	2-part wire rope	10	1/6	16	13 3/4	4 3/8	6 3/8	14 1/4	19

**NOTE:** For complete dimensional data, refer to Coffing Dimensional Databook.

**EMC and EMW (Hook Mount) 300 & 500 Lb. - EMC**  
**500 Lb. - EMW**

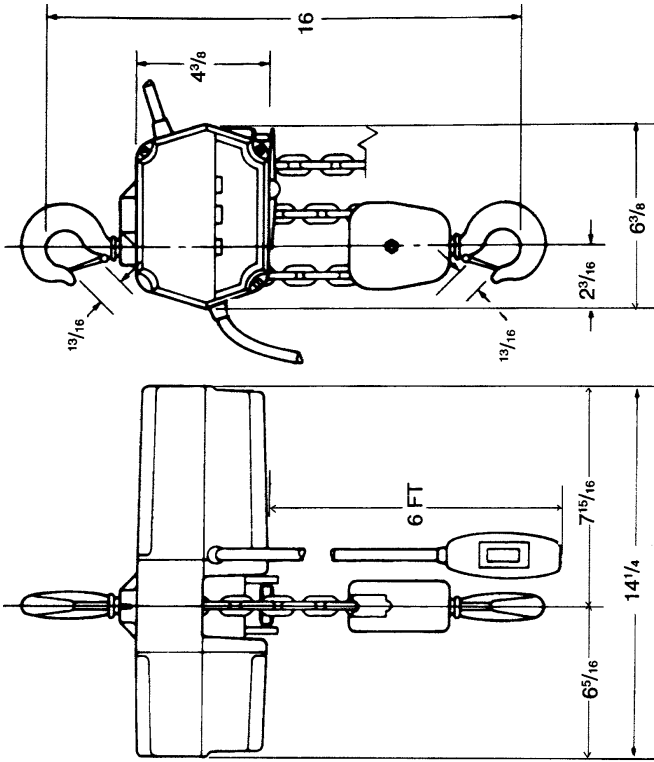

**EMC-500B**

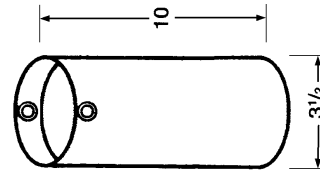

**Chain Container**  
for EMC models;  
vinyl-coated nylon  
fabric construction  
— order model  
no. LCC-05.

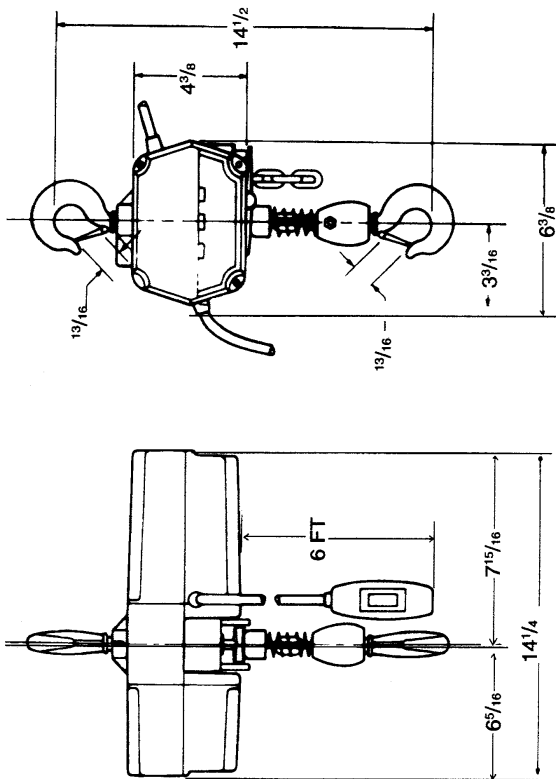

**EMC-300B**

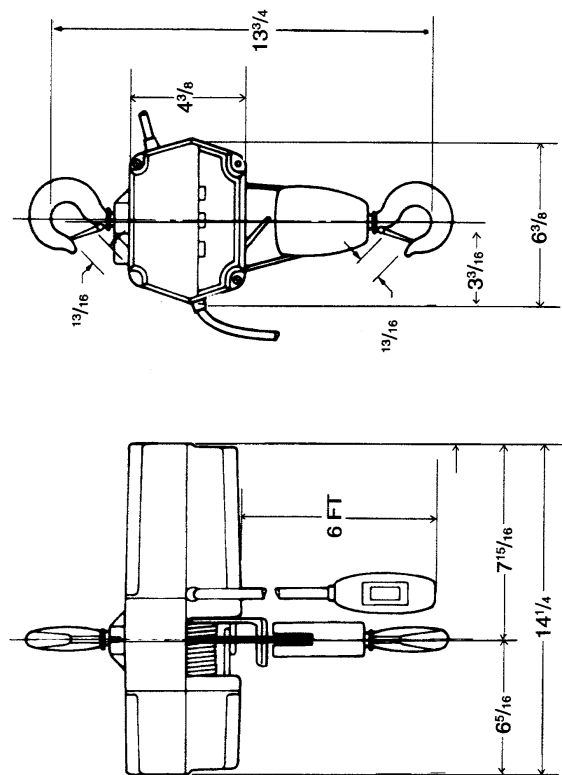

**EMW-500B**