

EC-1 (Motorized Trolley) ECMT-0516 to ECMT-1032 (1/4 to 1/2 Ton) Single Chain (Parallel Mounted)

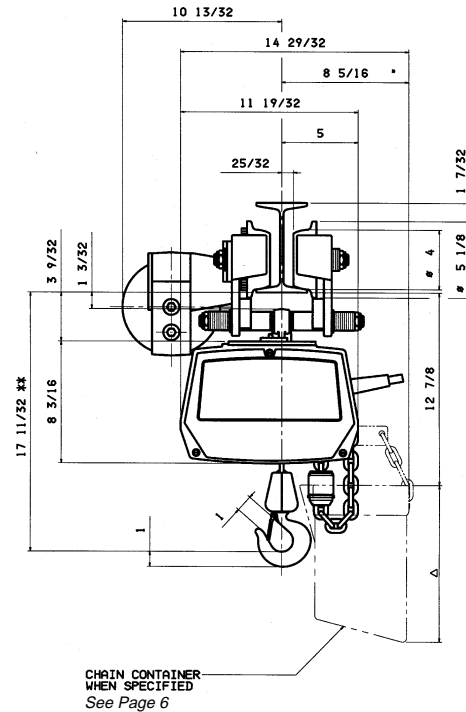

EC-1 (Motorized Trolley) ECMT-2012 and ECMT-2016 (1 Ton) Single Chain (Parallel Mounted)

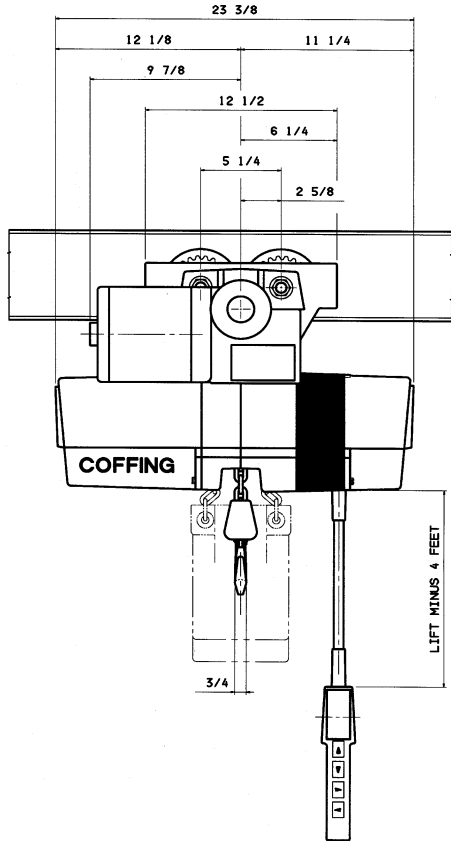
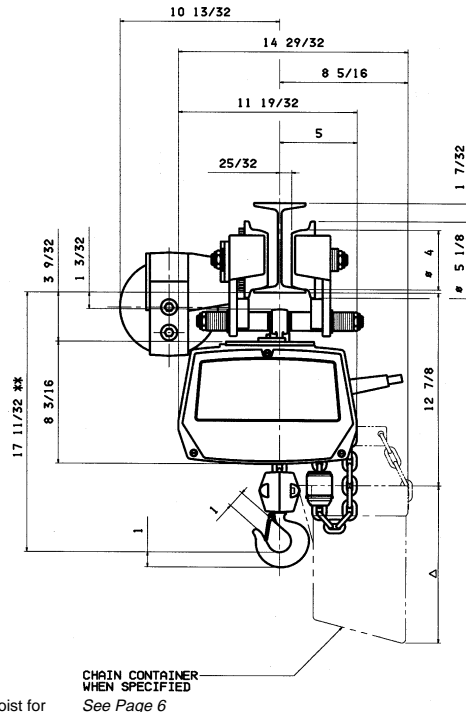
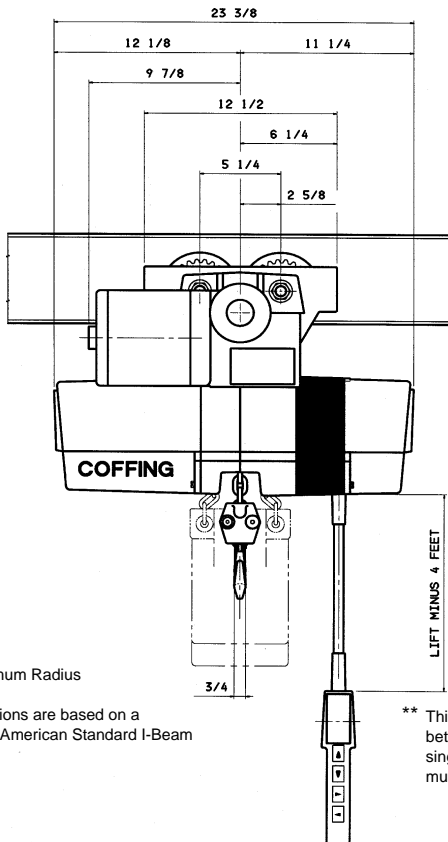

4 Ft. Minimum Radius

All dimensions are based on a
6" x 12.5# American Standard I-Beam

** This dimension allows for 2" clearance
between load block and underside of hoist for
single chain models and 1" clearance for
multiple chain models.

EC-1 (Motorized Trolley) ECMT-2004 and ECMT-2008 (1 Ton) Double Chain (Parallel Mounted)

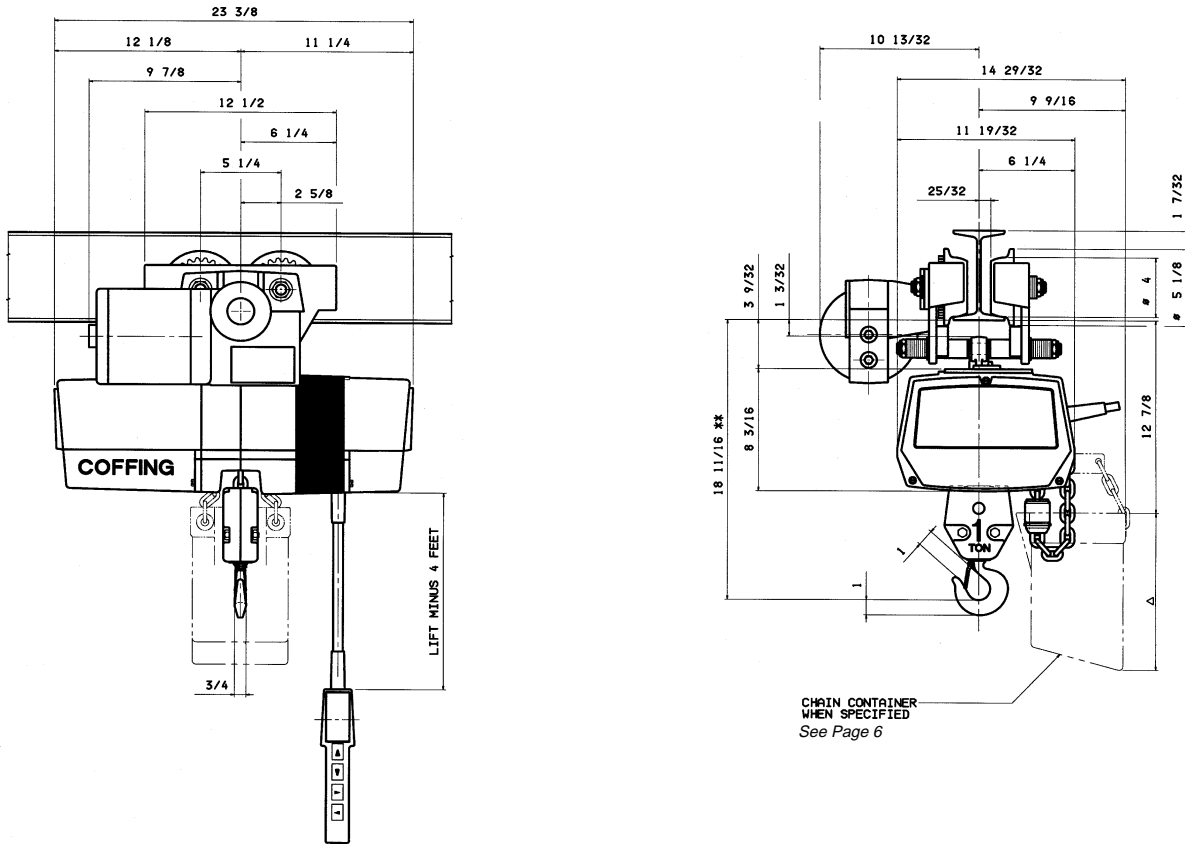

EC-1 (Motorized Trolley) ECMT-4006 and ECMT-4008 (2 Ton) Double Chain (Parallel Mounted)

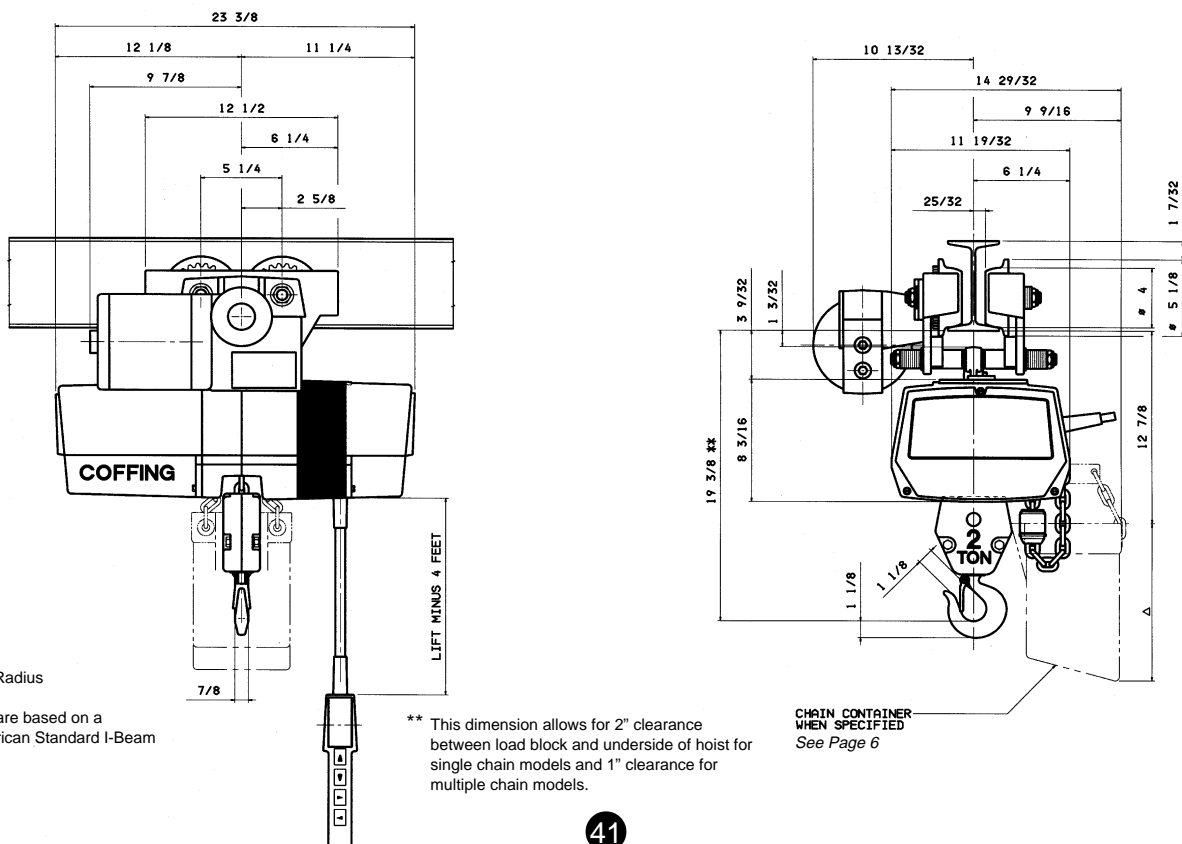

4 Ft. Minimum Radius

All dimensions are based on a 6" x 12.5# American Standard I-Beam

** This dimension allows for 2" clearance between load block and underside of hoist for single chain models and 1" clearance for multiple chain models.

EC-1 (Motorized Trolley) ECMT-6005 (3 Ton) Triple Chain (Parallel Mounted)

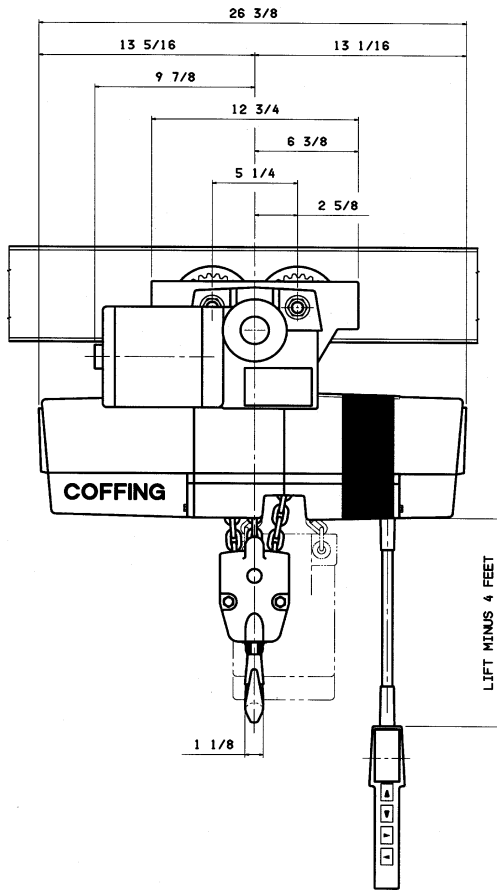

4 Ft. Minimum Radius

All dimensions are based on a 6" x 12.5# American Standard I-Beam

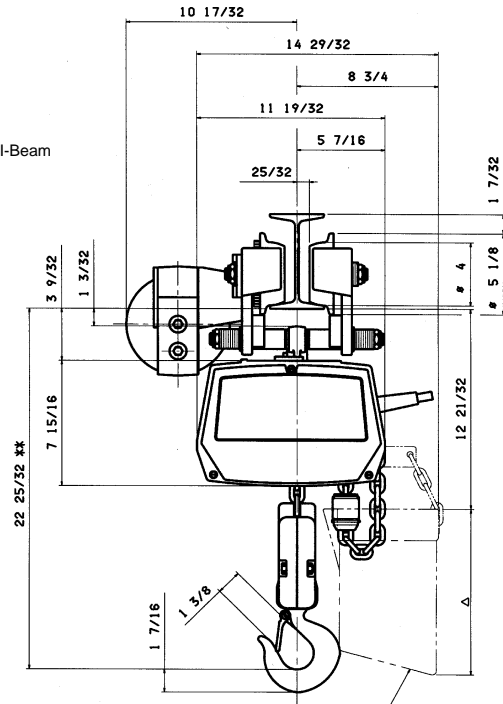

CHAIN CONTAINER
WHEN SPECIFIED
See Page 6

** This dimension allows for 2" clearance between load block and underside of hoist for single chain models and 1" clearance for multiple chain models.

EC-3 (Motorized Trolley) ECMT-2032 (1 Ton), ECMT-4016, ECMT-4024 (2 Ton) (Cross Mounted)

Single Chain

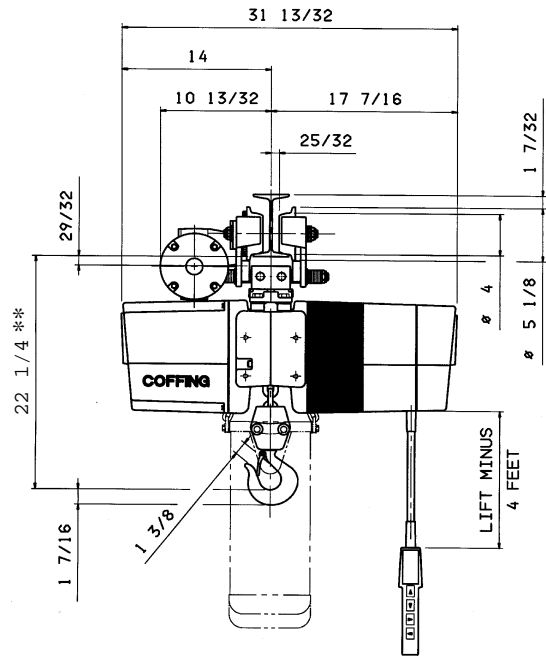
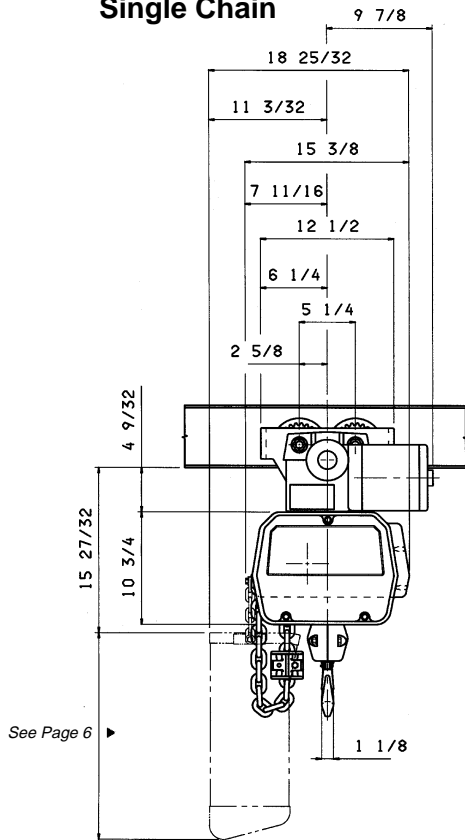

EC-3 (Motorized Trolley) ECMT-6010, ECMT-6016 (3 Ton) (Cross Mounted) Double Chain

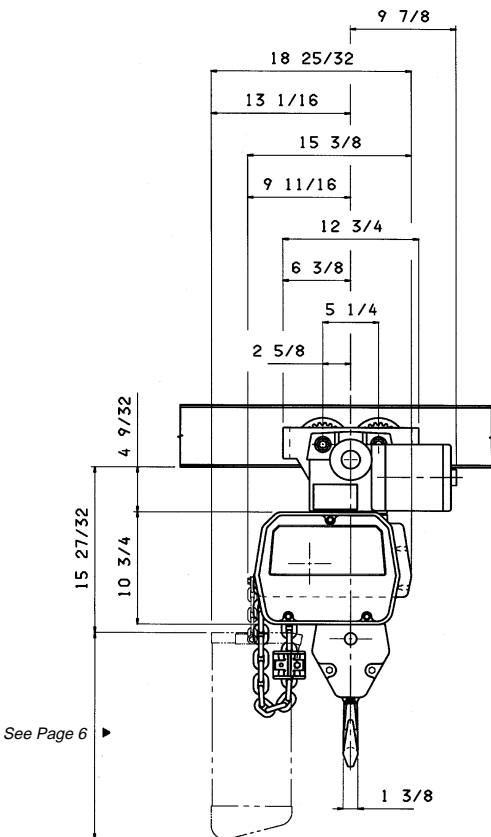

4 Ft. Minimum Radius

All dimensions are based on a
6" x 12.5# American Standard I-Beam

** This dimension allows for 2" clearance
between load block and underside of hoist for
single chain models and 1 1/2" clearance for
double chain models.

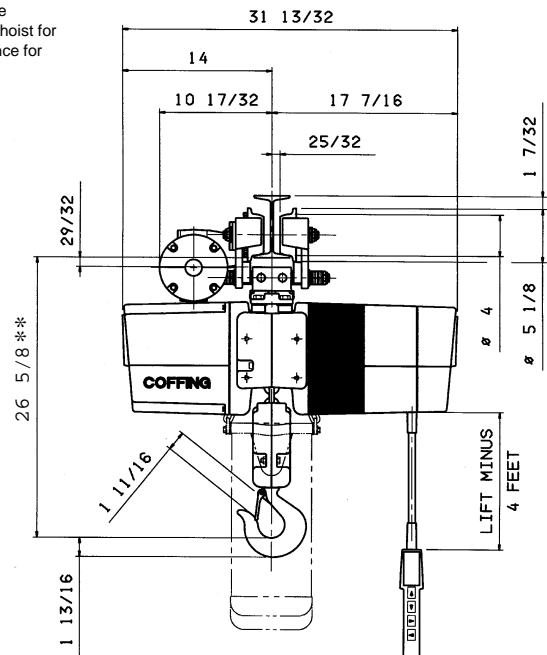

EC-3 (Motorized Trolley) ECMT-8008, ECMT-8012 (4 Ton)
(Cross Mounted) Double Chain

STRAIGHT TRACK ONLY

All dimensions are based on a
8" x 18.4# American Standard I-Beam

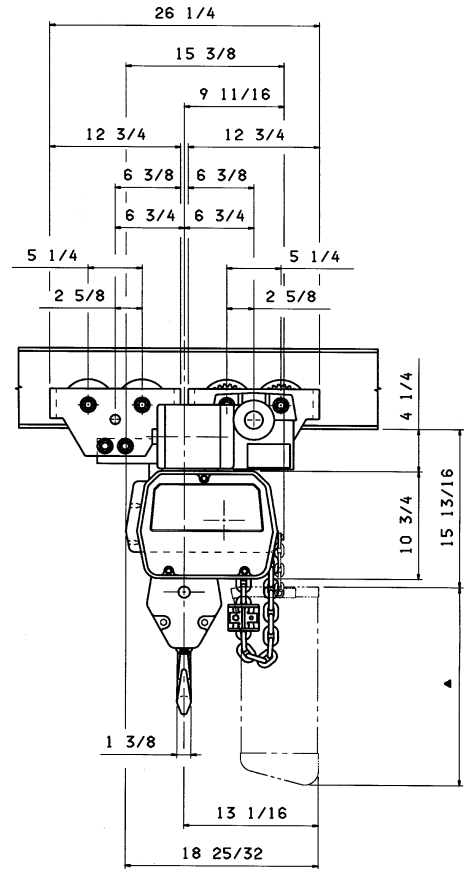
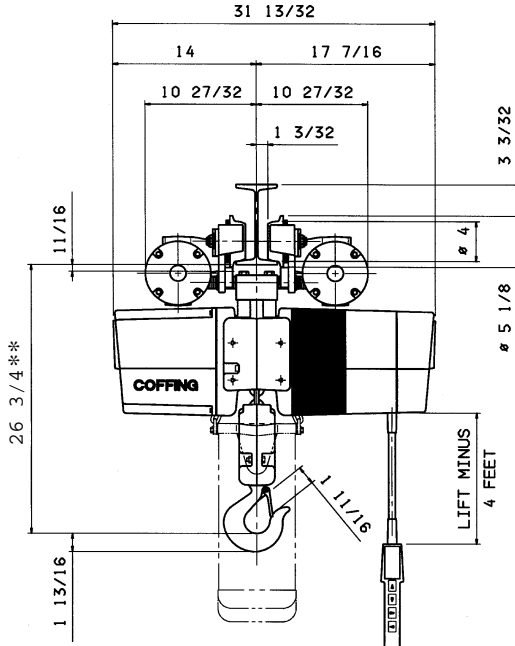

See Page 6

EC-3 (Motorized Trolley) ECMT-10005, ECMT-10008 (5 Ton)
(Cross Mounted) Triple Chain

STRAIGHT TRACK ONLY

All dimensions are based on a
8" x 18.4# American Standard I-Beam

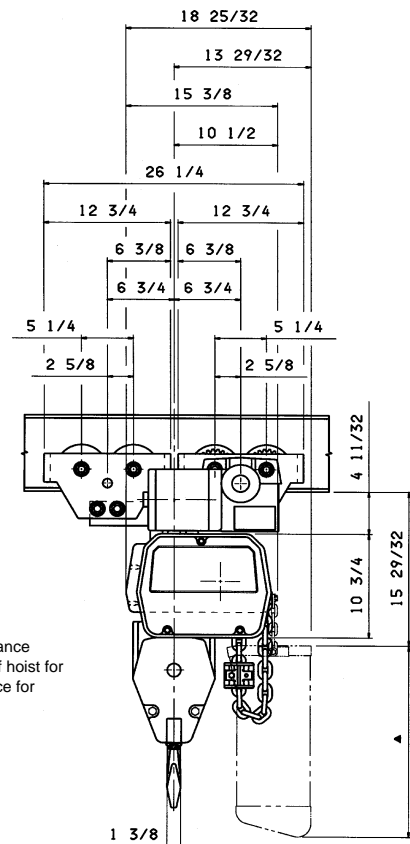
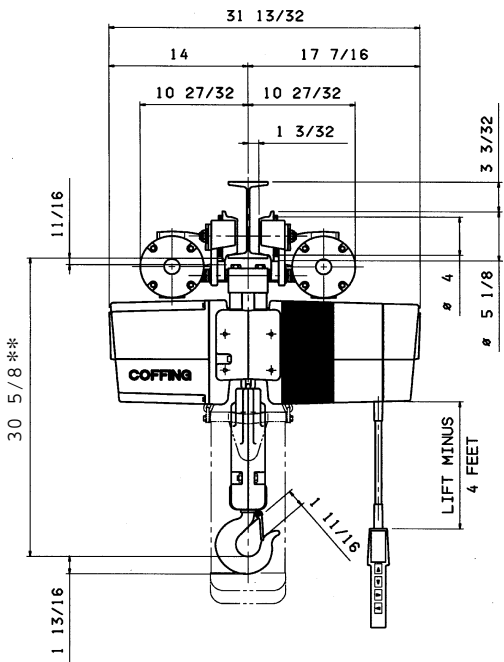

See Page 6

** This dimension allows for 1/2" clearance between load block and underside of hoist for double chain models and 1" clearance for triple chain models.