

EC-1 (Geared Trolley) ECGT-0516 to ECGT-1032 (1/4 to 1/2 Ton) Single Chain (Parallel Mount)

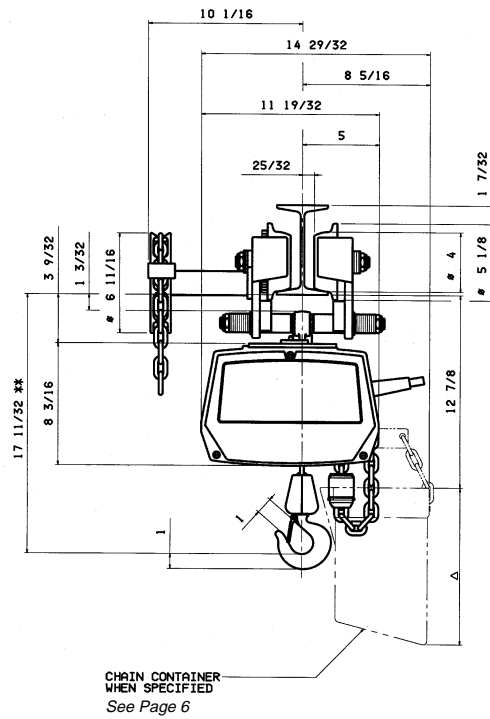

EC-1 (Geared Trolley) ECGT-2012 and ECGT-2016 (1 Ton) Single Chain (Parallel Mount)

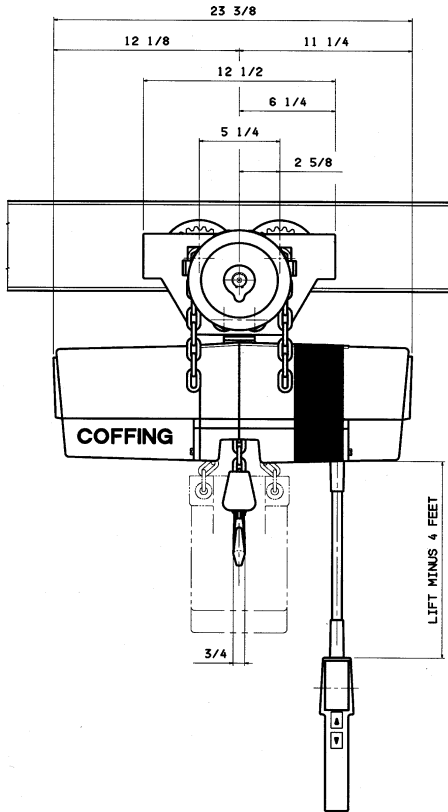
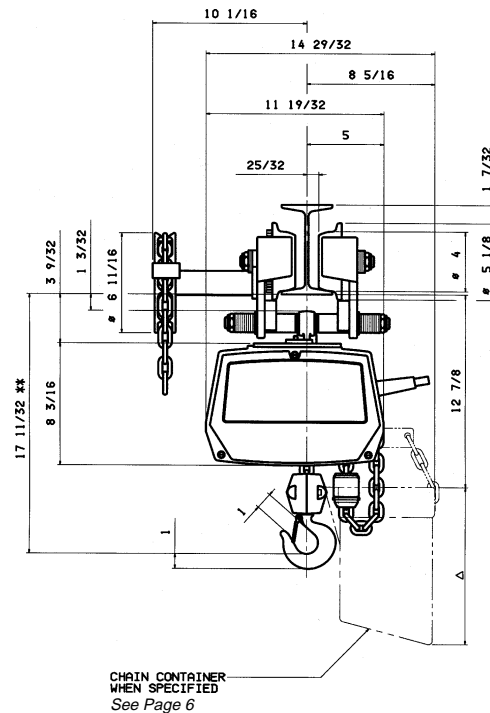
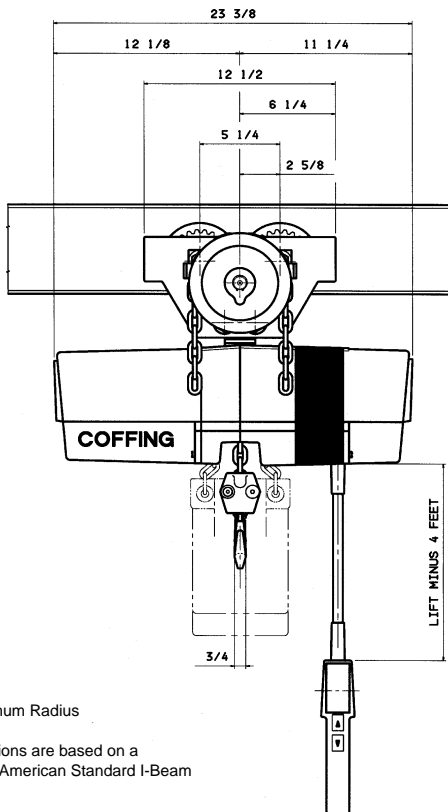

4 Ft. Minimum Radius

All dimensions are based on a 6" x 12.5# American Standard I-Beam

** This dimension allows for 2" clearance between load block and underside of hoist for single chain models and 1" clearance for multiple chain models.

EC-1 (Geared Trolley) ECGT-2004 and ECGT-2008 (1 Ton) Double Chain (Parallel Mount)

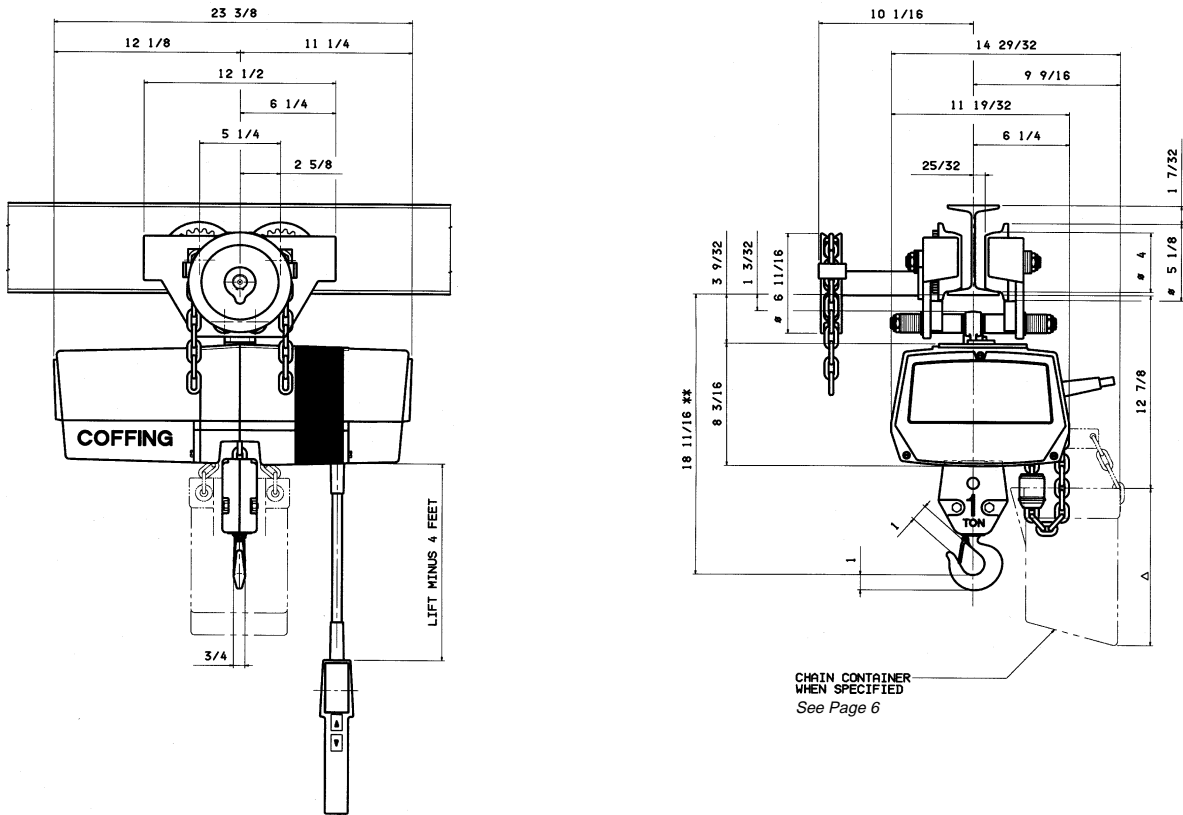

EC-1 (Geared Trolley) ECGT-4006 and ECGT-4008 (2 Ton) Double Chain (Parallel Mount)

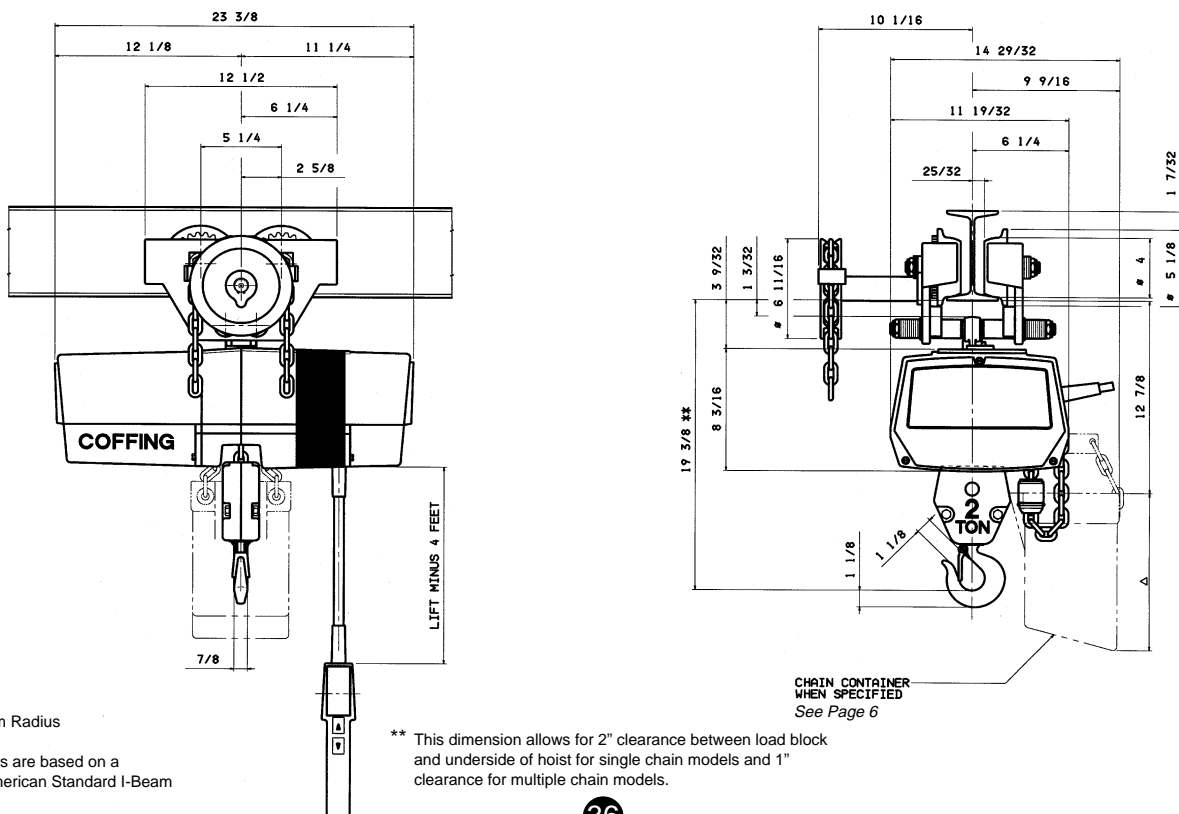

4 Ft. Minimum Radius

All dimensions are based on a
6" x 12.5# American Standard I-Beam

** This dimension allows for 2" clearance between load block
and underside of hoist for single chain models and 1"
clearance for multiple chain models.

EC-1 (Geared Trolley) ECGT-6005 (3 Ton) Triple Chain (Parallel Mount)

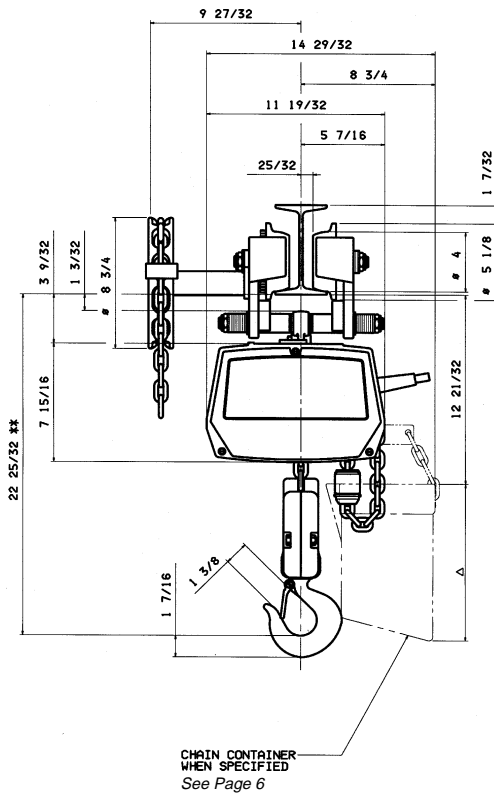
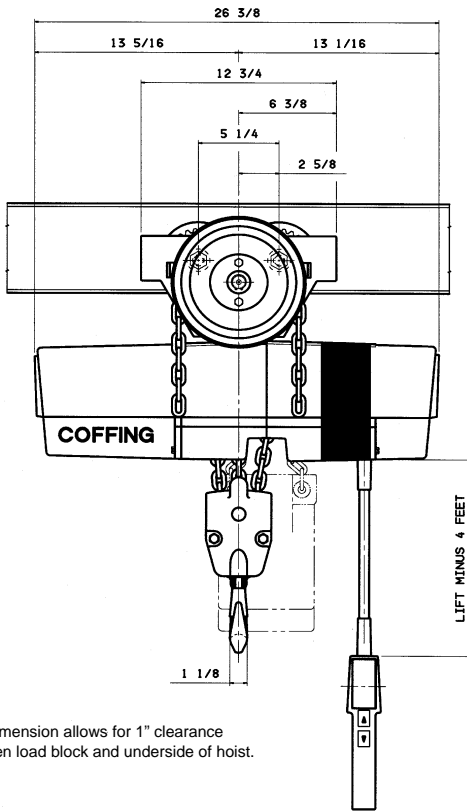

** This dimension allows for 1" clearance between load block and underside of hoist.

EC-3 (Geared Trolley) ECGT-2032 (1 Ton), ECGT-4016, ECGT-4024 (2 Ton) (Parallel Mount)

Single Chain

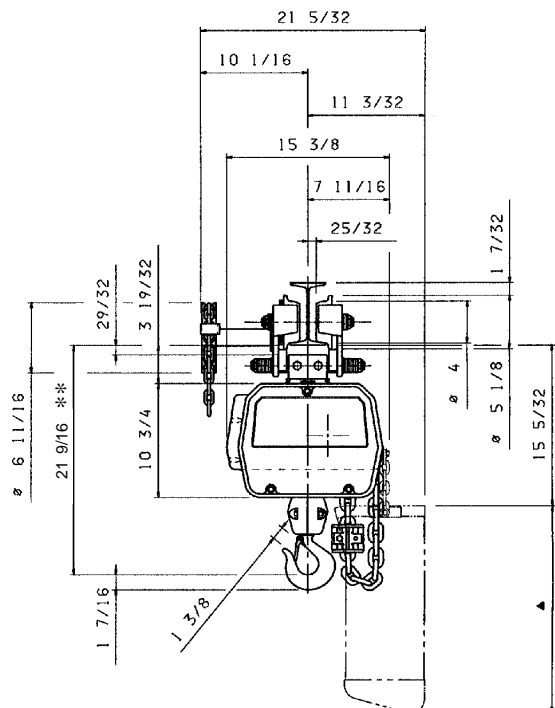
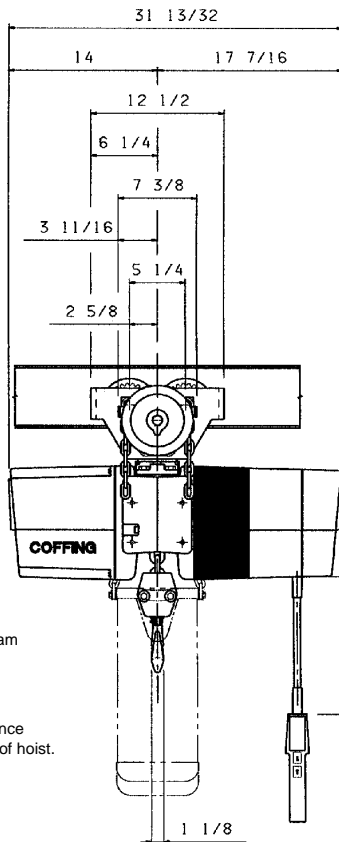

4 Ft. Minimum Radius

All dimensions are based on a 6" x 12.5# American Standard I-Beam

** This dimension allows for 2" clearance between load block and underside of hoist.

EC-3 (Geared Trolley) ECGT-6010, ECGT-6016 (3 Ton) (Parallel Mount) Double Chain

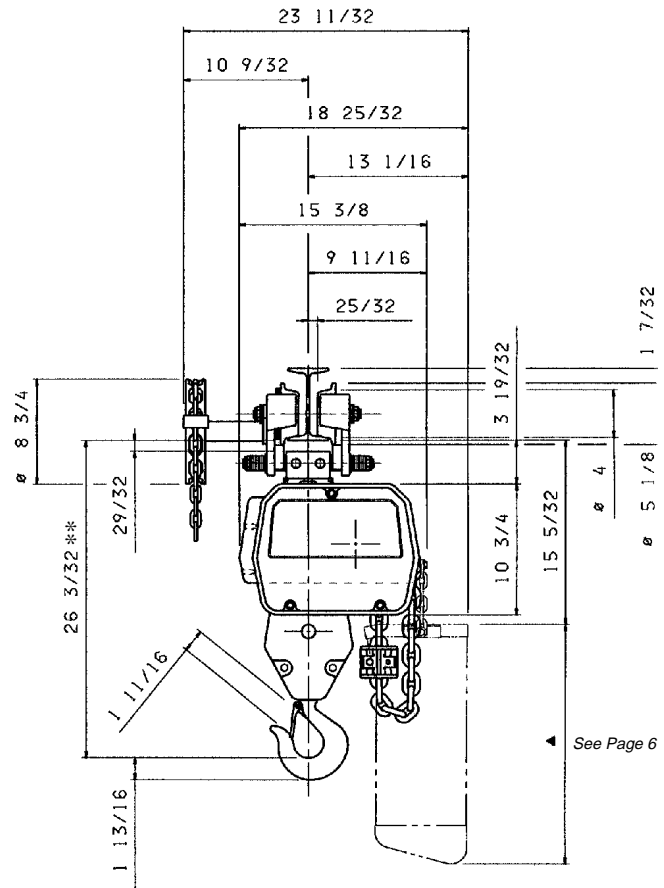
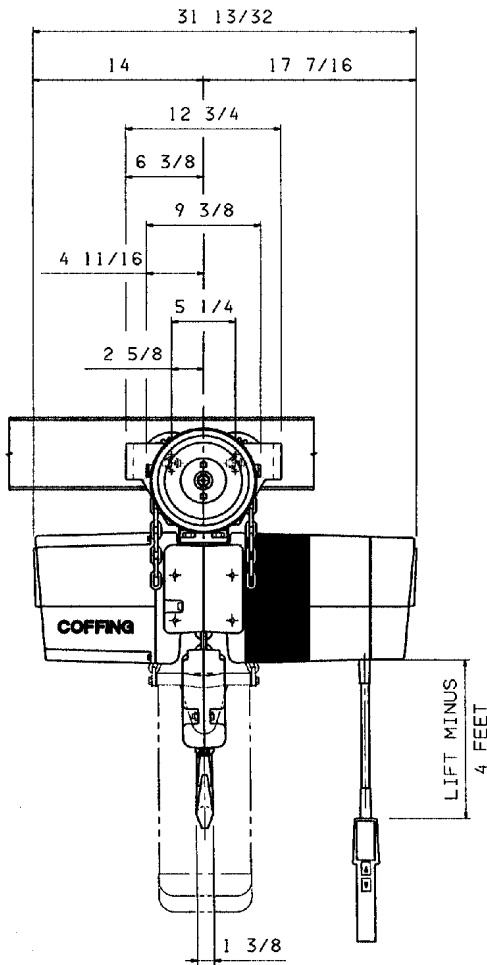

4 Ft. Minimum Radius

All dimensions are based on a
6" x 12.5# American Standard I-Beam

** This dimension allows for 1" clearance
between load block and underside of hoist.

EC-3 (G geared Trolley) ECGT-8008, ECGT-8012 (4 Ton) (Cross Mounted) Double Chain

STRAIGHT TRACK ONLY

All dimensions are based on a
8" x 18.4# American Standard I-Beam

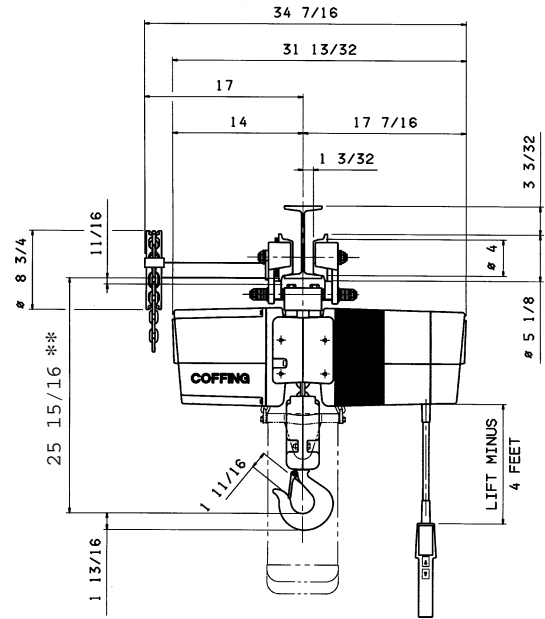
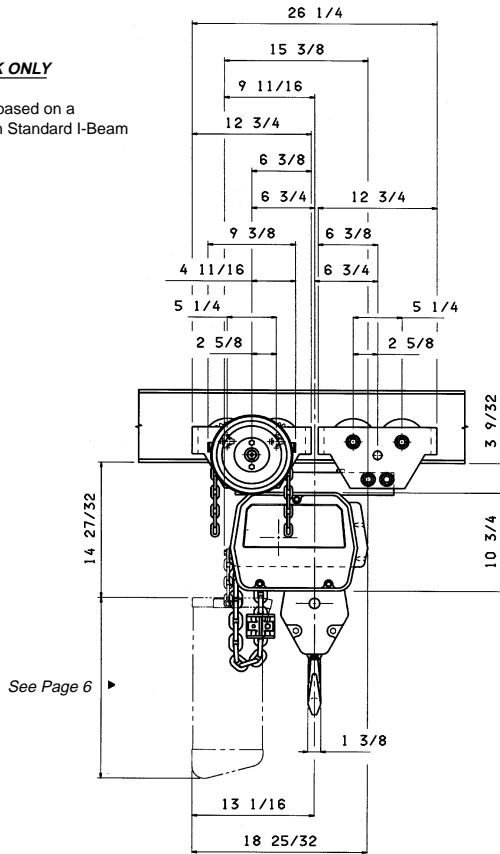

EC-3 (G geared Trolley) ECGT-10005, ECGT-10008 (5 Ton) (Cross Mounted) Triple Chain

STRAIGHT TRACK ONLY

All dimensions are based on a
8" x 18.4# American Standard I-Beam

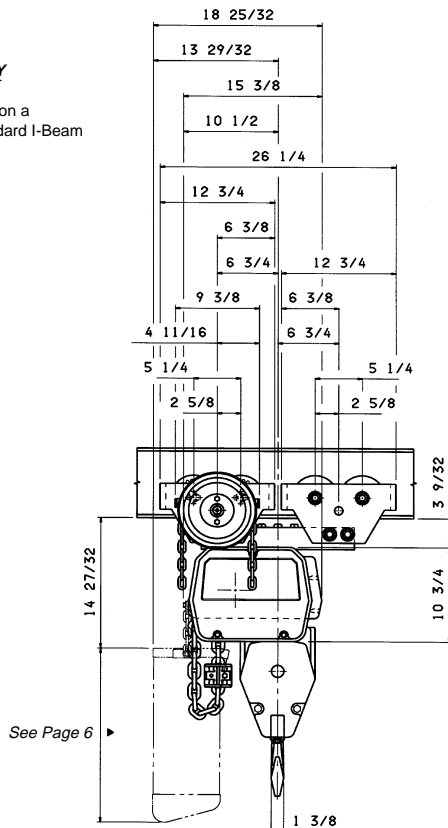

** This dimension allows for 1 1/2" clearance between load block and underside of hoist for double chain models and 1" clearance for triple chain models.

